

No communications power supply shall be mounted on Poles except by permission of Utility.

Licensee's Attachments on Utility Poles, including metal attachment clamps and bolts, metal cross arm supports, bolts and other equipment, must be attached so as to maintain the minimum separations specified in the NESC and in these drawings and specifications.

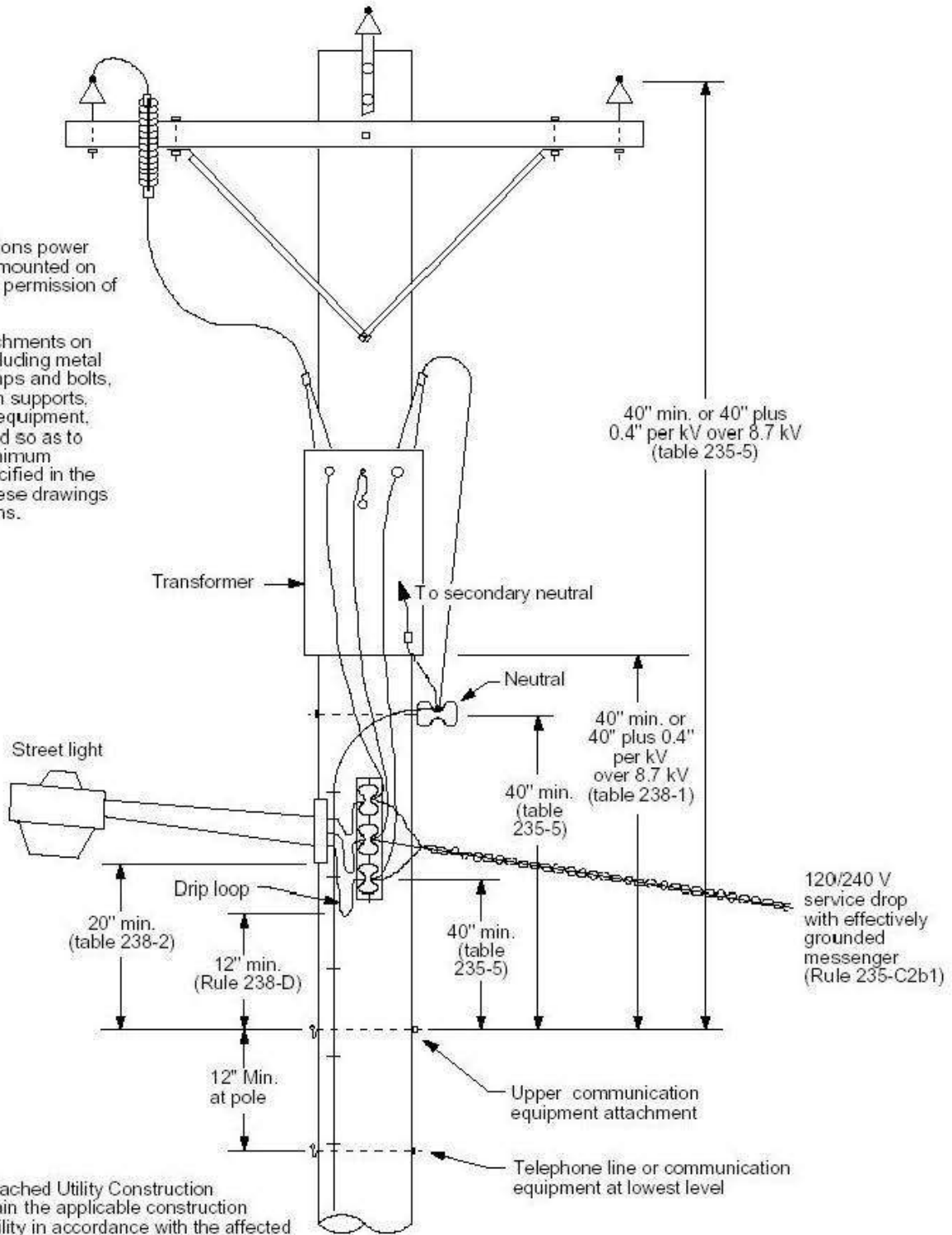

NOTES:

1. Refer to the attached Utility Construction Standards, or obtain the applicable construction standards from Utility in accordance with the affected Utility's requirements.
2. Apply the Utility Construction Standards in coordination of the applicable NESC, NEC or State Statute code requirements.
3. See Drawing 02 for additional notes.

Contact Utility for 480 volt installations

A	Revised 9/6/02
---	----------------

POLE ATTACHMENTS	
OVERHEAD MINIMUM CLEARANCES	
Drawing is NOT to scale	A-01

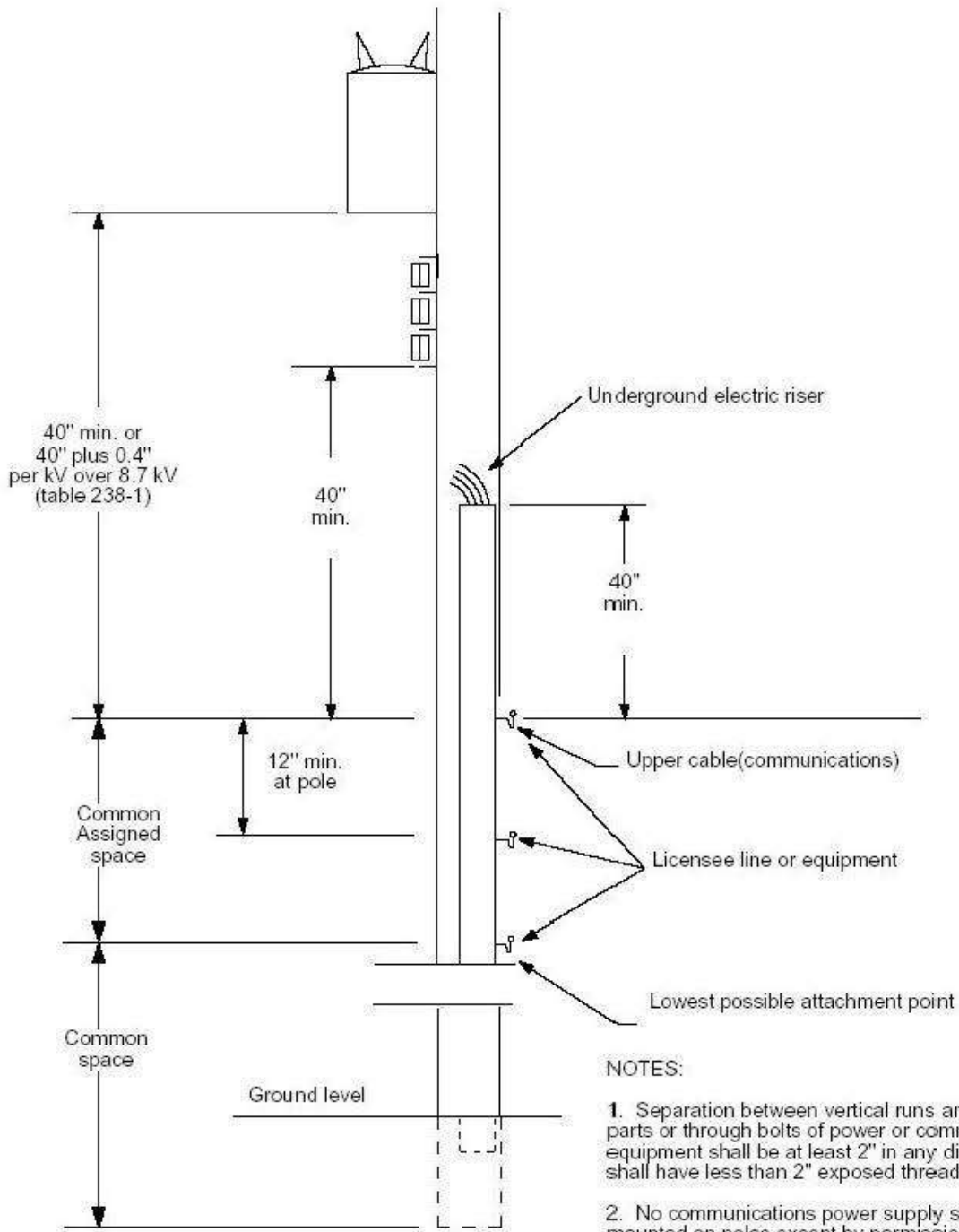

NOTES:

1. Separation between vertical runs and any metal parts or through bolts of power or communication equipment shall be at least 2" in any direction. Bolts shall have less than 2" exposed thread.
2. No communications power supply shall be mounted on poles except by permission of Utility.
3. The above clearances may have to be increased to allow for code clearance requirement in mid span.
4. Licensee's Attachments on Utility poles, including metal attachment clamps and bolts, metal cross arm supports, bolts and other equipment, must be attached so as to maintain the minimum separations specified in the NESC and in these drawings and specifications.

A	Revised 9/6/02
---	----------------

POLE ATTACHMENTS	
OVERHEAD MINIMUM CLEARANCES	
Drawing is NOT to scale	A-02

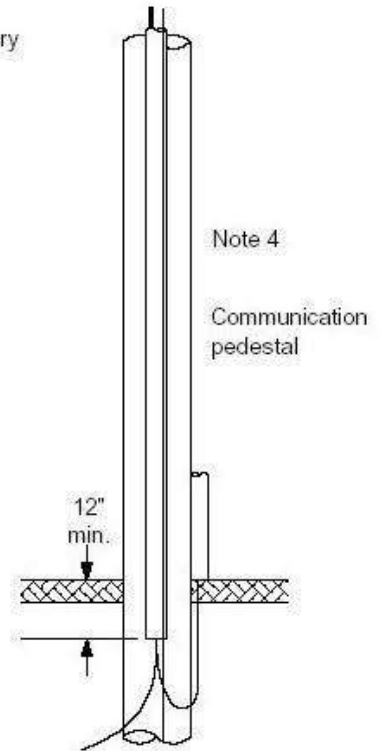
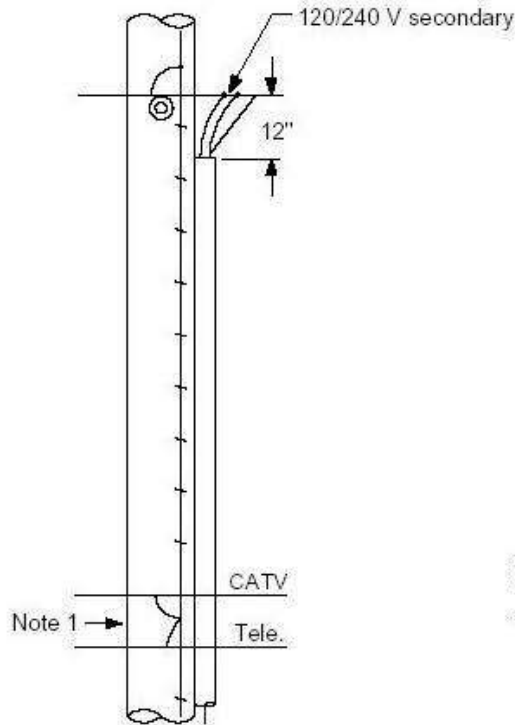
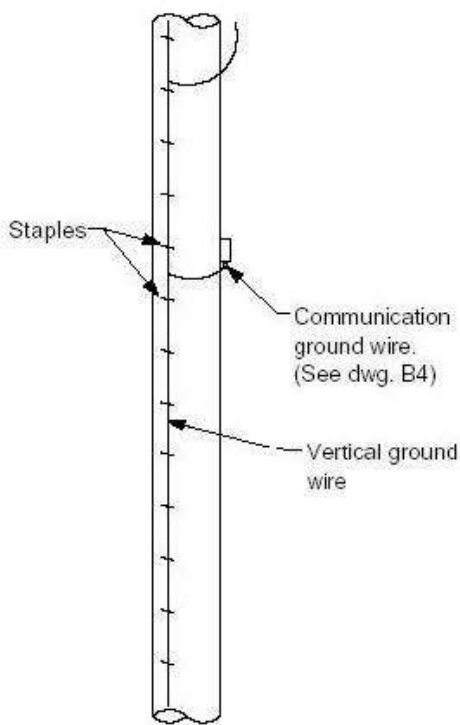

NOTES:

No communications power supply shall be mounted on Poles except by permission of Utility.

Licensee's Attachments on Utility Poles, including metal attachment clamps and bolts, metal cross arm supports, bolts and other equipment, must be attached so as to maintain the minimum separations specified in the NESC and in these drawings and specifications.

See Drawing #5

1. Licensee shall bond to Utility pole ground wherever Utility has a down ground on the pole. If the ground is under the metal U-guard, contact Utility to make the ground connection.
2. If no pole ground exists install a pole down ground on the pole. Protect the pole ground with a ground wire moulding. Top of ground rod shall be at least 6 inches below grade.
3. Bond wire shall be #6 bare copper or larger. If bond wire is unsupported for more than 12" long, staple to pole.
4. When communication's are underground, the power is overhead and it is required that the communications ground be interconnected to the power supply ground, the connection shall be made below grade.
5. In no case shall Licensee ground be connected to guys/anchors.
6. If a neutral isolation device is installed on this pole the attacher must contact Utility for special grounding instructions.
7. Licensee's messenger cable shall be bonded to Utility's pole ground wire at each pole that has a ground wire.

A	Revised 9/6/02
POLE ATTACHMENTS	
GROUNDING CONNECTIONS	
Drawing is NOT to scale	A-03

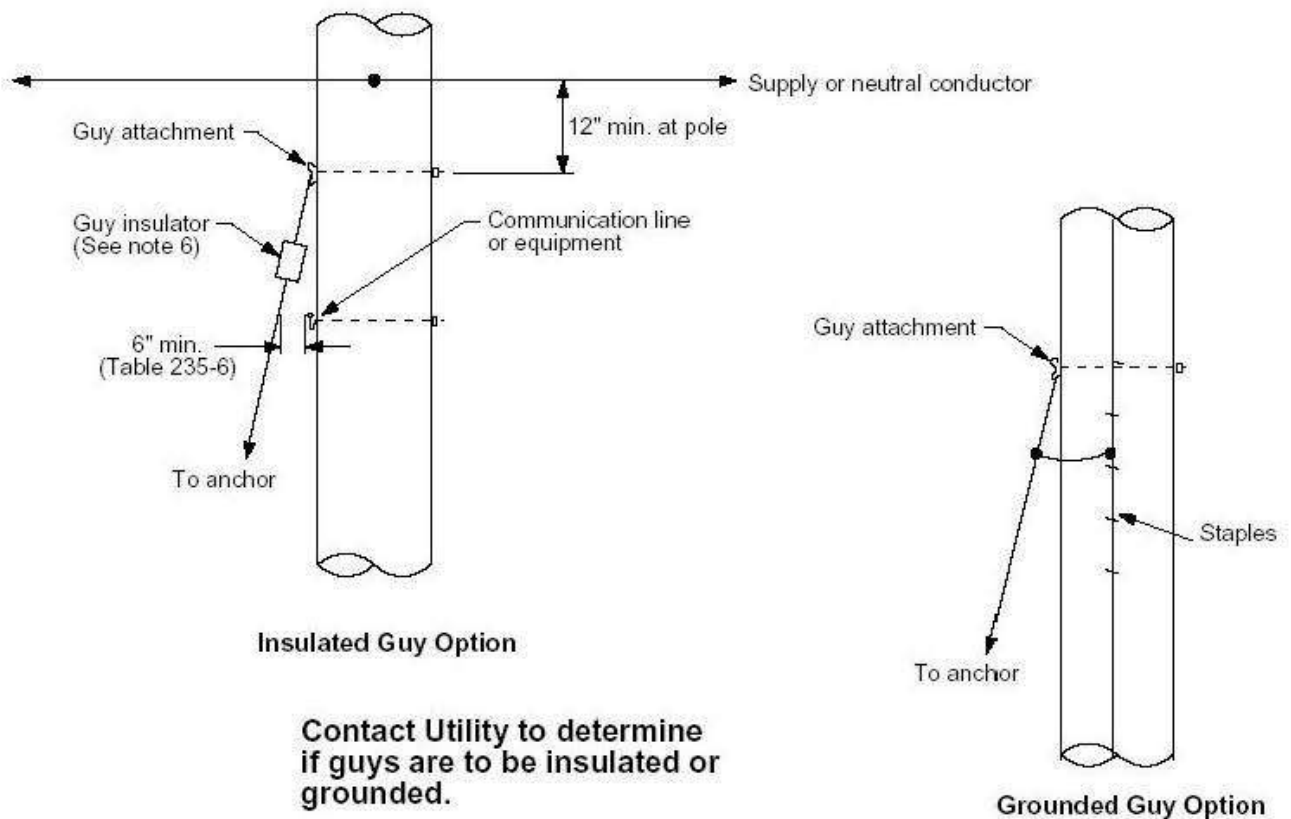

NOTES:

1. Licensee shall be responsible for procuring and installing all anchors and guy wires to support the additional stress placed on Utility's poles by Licensee's Attachments.
2. Anchors and guy wires must be set on each Utility pole where there is a turn or angle and on all dead-end Utility poles.
3. Licensee may not place guy wires on the anchors of Utility or Third Party User without prior written consent of all attaching entities and anchor owners.
4. No Attachment may be installed on a Utility pole until all required guys and anchors are installed, nor may any Attachment be modified or relocated in such a way as will materially increase the stress or loading on Utility poles until all required guys and anchors are installed.
5. Licensee's down guys shall not be bonded to ground or neutral wires of Utility's pole and shall not provide a current path to ground from the pole ground or power system neutral. If permitted or required by the Utility, grounded guys should be installed.
6. On jointly used structures, guys that pass within 12" of supply conductors, and also pass within 12" of communication cables, shall be protected with a suitable insulating covering where the guy passes the supply conductors, unless the guy is effectively grounded or insulated with a strain insulator at a point below the lowest supply conductor and above the highest communication cable.

No communications power supply shall be mounted on poles except by permission of Utility.

Licensee's Attachments on Utility Poles, including metal attachment clamps and bolts, metal cross arm supports, bolts and other equipment, must be attached so as to maintain the minimum separations specified in the NESC and in these drawings and specifications.

A	Revised 9/6/02
POLE ATTACHMENTS	
GUY WIRE REQUIREMENTS	
Drawing is NOT to scale	A-04

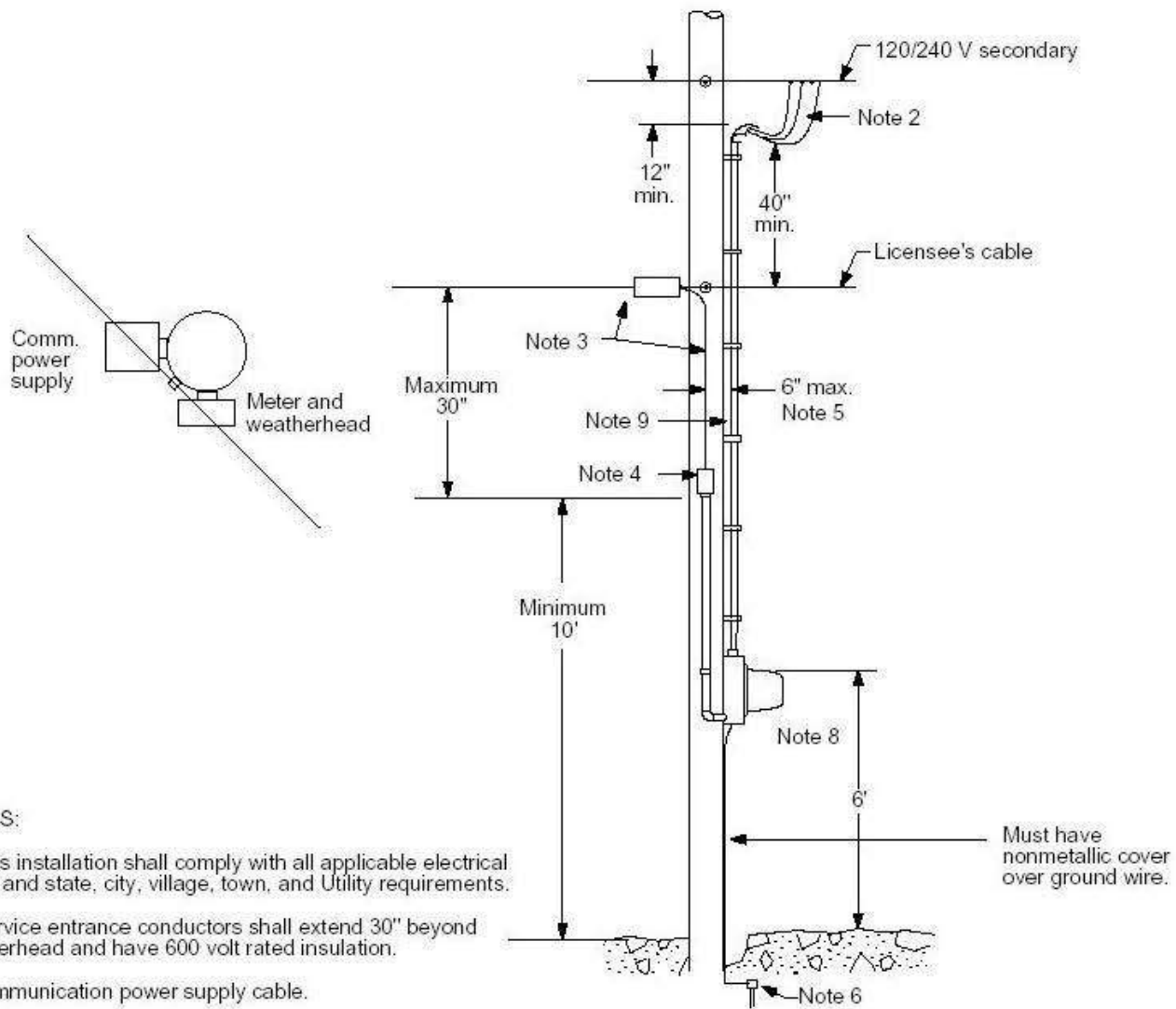

NOTES:

1. This installation shall comply with all applicable electrical codes and state, city, village, town, and Utility requirements.
2. Service entrance conductors shall extend 30" beyond weatherhead and have 600 volt rated insulation.
3. Communication power supply cable.
4. Communication power supply.
5. 6" maximum between service entrance conduit and communications cable, if possible.
6. Grounding shall be in accordance with National Electric Code article 250. Top of rod to be 6" below grade.
7. Location of all Licensee equipment is to be approved by Utility and shall be relocated by Licensee if incorrect.
8. Proof of compliance shall be appropriately certified. Install disconnect and overcurrent protection with meter.
9. All risers on poles will be placed in rigid steel or aluminum metallic conduit on the quarter faces of the pole.
10. This service detail applies to all commercial users requiring power for pole mounted devices.

No communications power supply shall be mounted on poles except by permission of Utility.

Licensee's Attachments on Utility Poles, including metal attachment clamps and bolts, metal cross arm supports, bolts and other equipment, must be attached so as to maintain the minimum separations specified in the NESC and in these drawings and specifications.

See Drawing #3

A	Revised 9/6/02
POLE ATTACHMENTS	
POWER SERVICE	
Drawing is NOT to scale	A-05

Copies of the NEC (National Electrical Code) can be obtained at the website of <http://www.nfpa.org>

Copies of the NESC (National Electric Safety Code) can be obtained at the website of <http://standards.ieee.org>

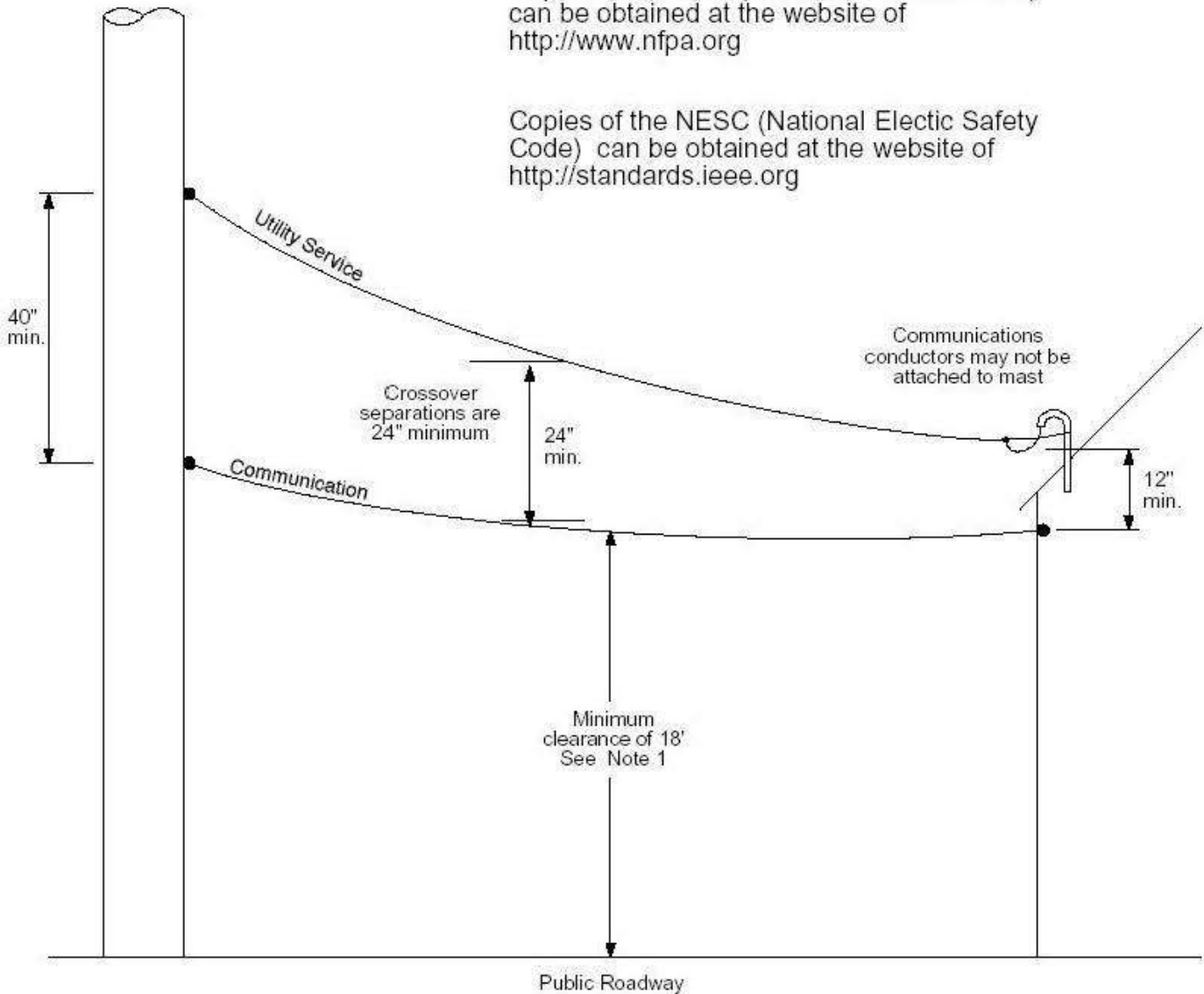

NOTES: (The NESC changes every three years, the clearances noted below have limiting conditions and may change. Refer to Section 232 of the NESC for latest requirements.)

1. Maintain minimum clearance
 - a) Railroads - 24'
 - b) Interstate - Contact State for specific requirements
 - b) Driveways - 16'
 - b) Walkways - 12'
2. Reference NESC clearances on same supporting structures
 - a) Section 235
 - b) Section 238
3. Reference NESC clearances on different supporting structures
 - a) Section 233

No communications power supply shall be mounted on poles except by permission of Utility.

Licensee's Attachments on Utility Poles, including metal attachment clamps and bolts, metal cross arm supports, bolts and other equipment, must be attached so as to maintain the minimum separations specified in NESC and in these drawings and specifications.

A

Revised 9/6/02

POLE ATTACHMENTS

MINIMUM CLEARANCE TO SERVICE AND ROADWAY

Drawing is NOT to scale

A-06

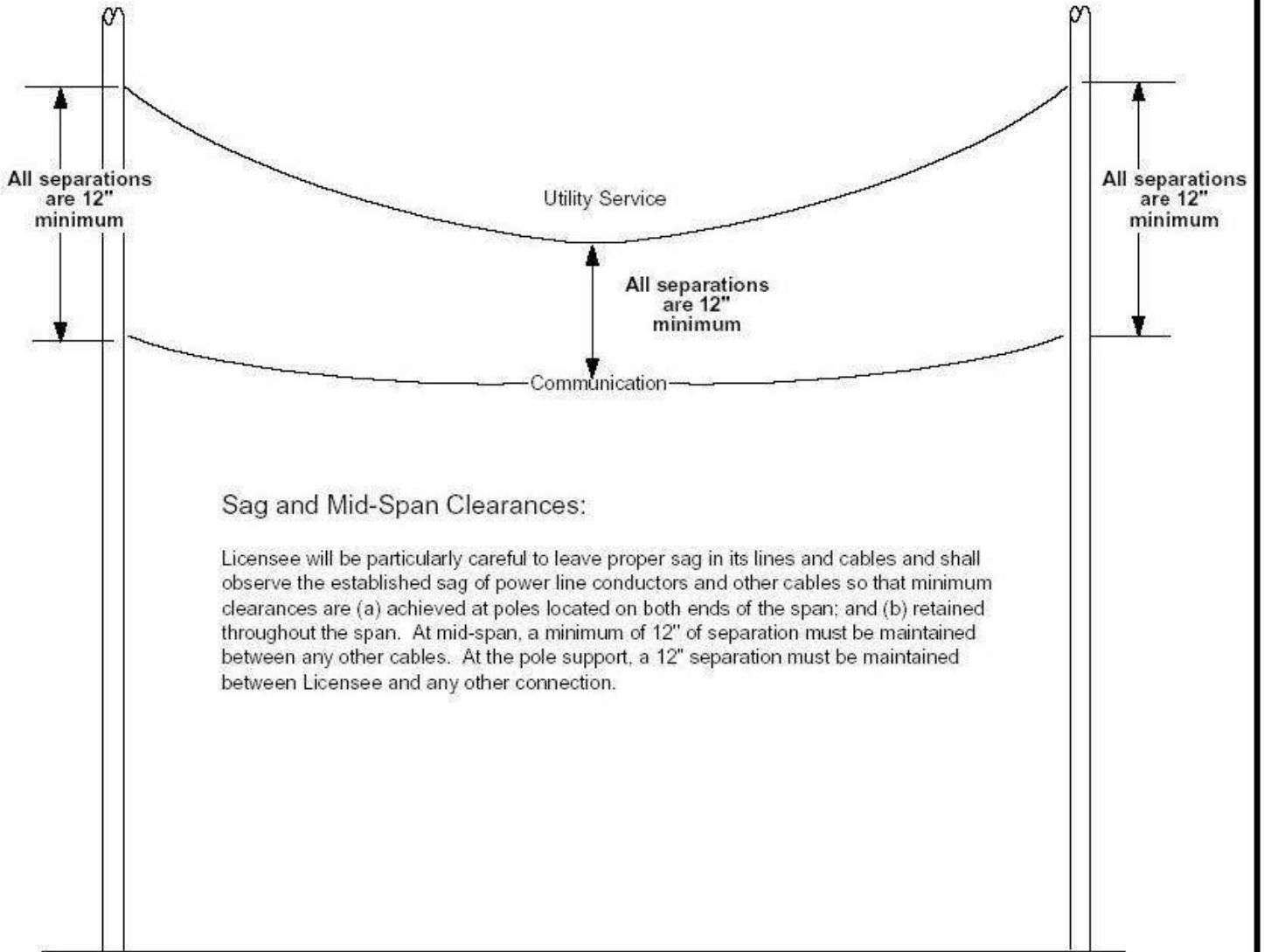

Copies of the NEC (National Electrical Code) can be obtained at the website of <http://www.nfpa.org>

Copies of the NESC (National Electric Safety Code) can be obtained at the website of <http://standards.ieee.org>

No communications power supply shall be mounted on poles except by permission of Utility.

Licensee's Attachments on Utility Poles, including metal attachment clamps and bolts, metal cross arm supports, bolts and other equipment, must be attached so as to maintain the minimum separations specified in the NESC and in drawings and specifications.

A	Revised 9/0602
---	----------------

POLE ATTACHMENTS	
MIN. CLEARANCE BETWEEN CIRCUITS	
Drawing is NOT to scale.	A-07

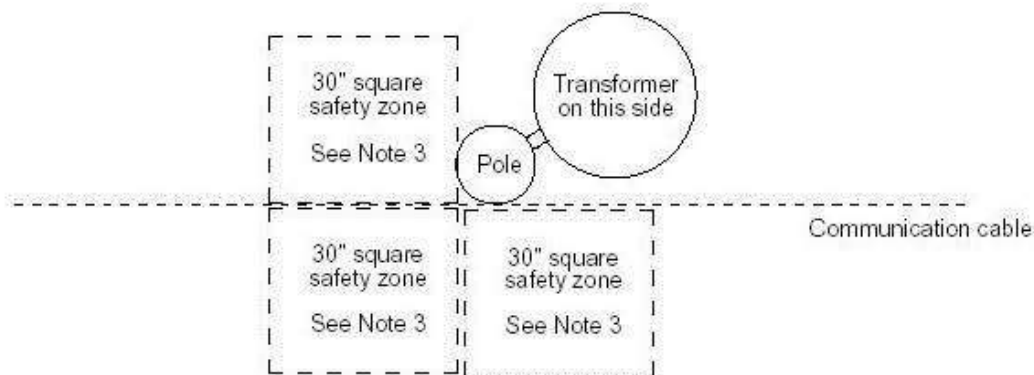

NOTES:

1. For new cable installations locate cable on the same side of the pole as Utility's lowest conductor.
2. Standoff brackets to mount cable to pole are not allowed without approval of Utility.
3. Climbing and workspace through the communication space shall extend from 40" below the lowest communication cable to the top of the pole.
4. On transformer poles the communication service drops shall be located so that they originate from the messenger on the side of the pole opposite the transformer.
5. Minimum clearances for climbing and working space shall be followed as per NESC section 236.

No communications power supply shall be mounted on poles except by permission of Utility.

Licensee's Attachments on Utility Poles, including metal attachment clamps and bolts, metal cross arm supports, bolts and other equipment, must be attached so as to maintain the minimum separations specified in the NESC and in these drawings and specifications.

A	Revised 9/6/02
---	----------------

POLE ATTACHMENTS	
CLIMBING SPACE REQUIREMENTS	
Drawing is NOT to scale	A-08

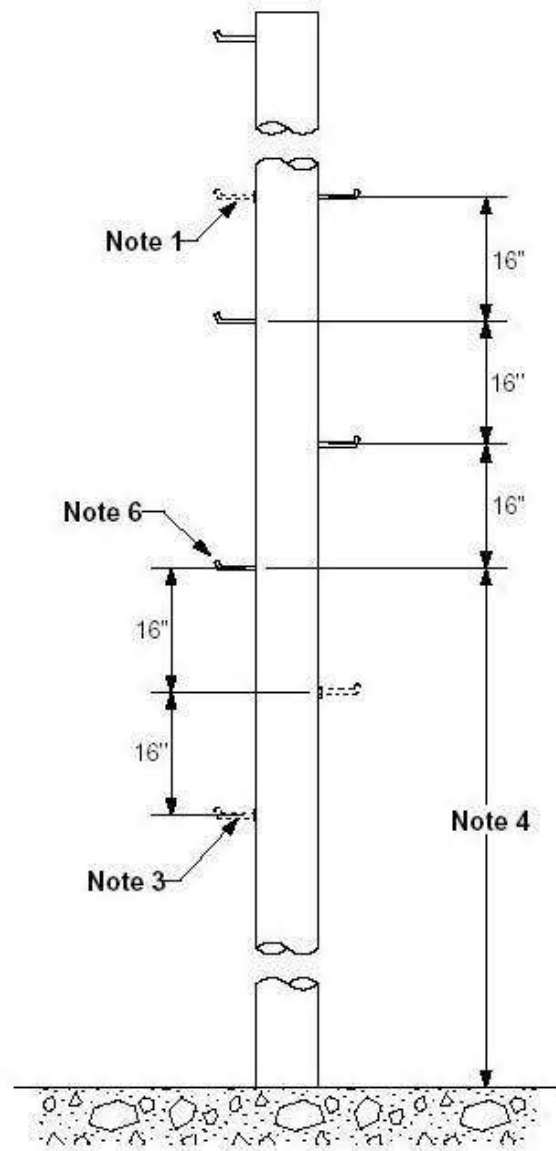

No communications power supply shall be mounted on poles except by permission of Utility.

Licensee's Attachments on Utility Poles, including metal attachment clamps and bolts, metal cross arm supports, bolts and other equipment, must be attached so as to maintain the minimum separations specified in the NESC and in these drawings and specifications.

Pole steps must be authorized by the Utility before installation.

NOTES:

If authorized, pole steps must meet the following requirements:

1. An additional step shall be placed opposite a step located where work is frequently performed.
2. Where pole is set close to a building with an accessible roof use detachable steps from the roof level up to a level 8 ft. above the roof.
3. Use detachable pole steps where steps are required below the 8 ft. level
4. Locate lowest hook pole step 8 ft. above the ground on distribution poles and 8 ft. above the ground on joint poles.

A	Revised 9/6/02
---	----------------

POLE ATTACHMENTS

POLE STEP REQUIREMENTS

Drawing is NOT to scale	A-09
-------------------------	-------------

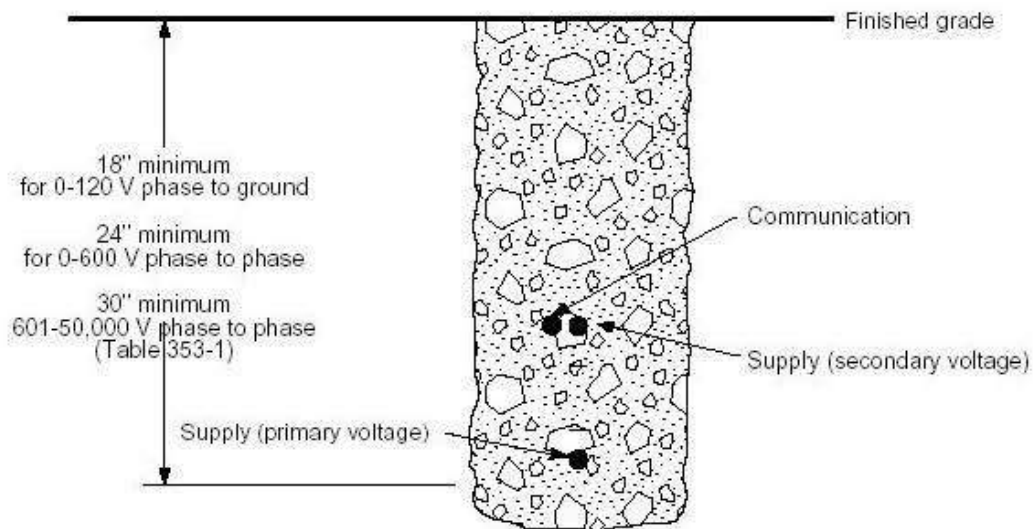

DIRECT BURIED- SEPARATION

NOTES:

1. Communications equipment shall meet requirements of NESC 354D.
2. Communications cables shall be random laid with primary and secondary cables as specified in NESC 354D.
3. The bonding conductor required in NESC shall be provided as part of the communications pedestal installation. A communications bonding conductor clamp of sufficient length for routing into the supply pedestal/transformer neutral connector shall be provided.
4. Installation may be by plowing, trenching, or backhoe as conditions warrant.

A	Revised 9/6/02
---	----------------

POLE ATTACHMENTS

JOINT CABLE INSTALLATION

Not more than 36" from pole centerline

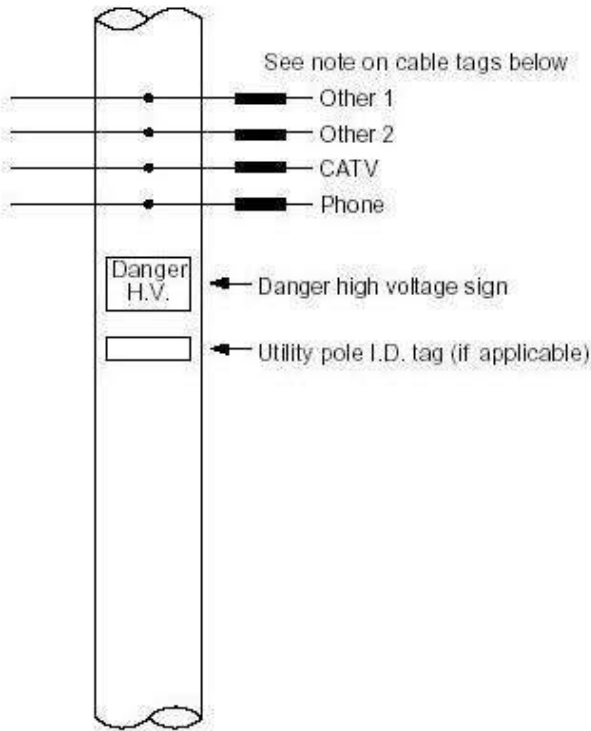

Suggested Method for Designated Poles (Subject to Utility approval)

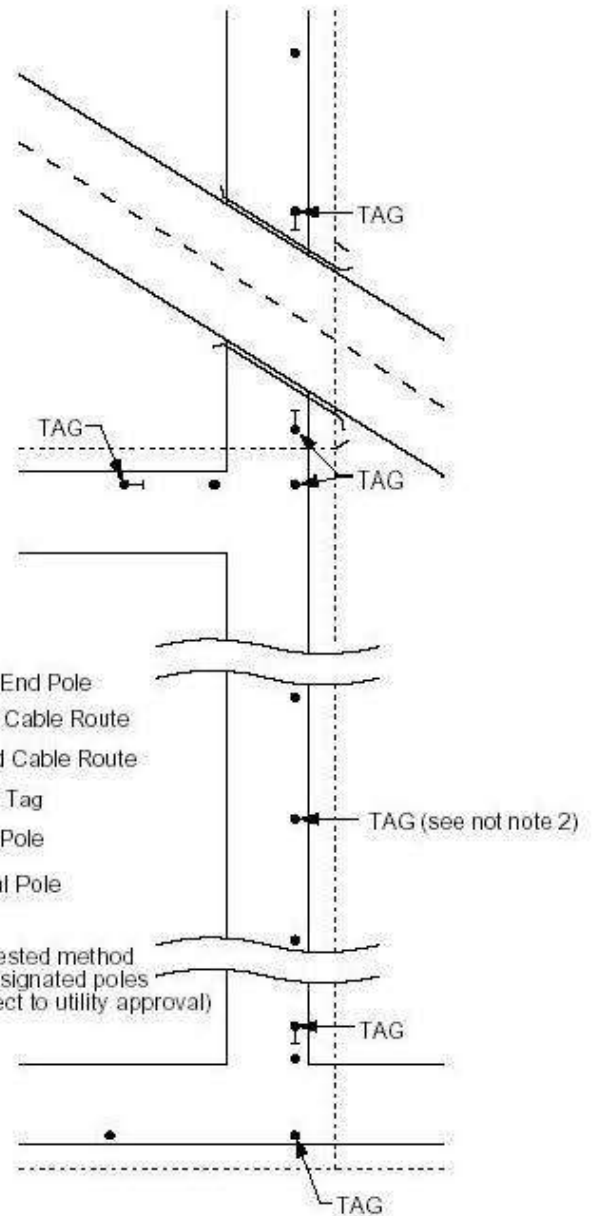

Preferred Attachment Identification Tag

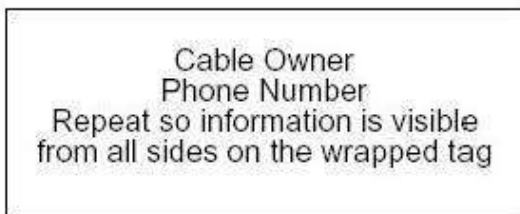

Rolled cable tag width to be 5 inches or greater, tag diameter sized to fit cable. All to be UV resistant material and printing.

NOTES:

1. Tags should be installed at lateral and dead-end poles and at the termination point of underground cable runs.
2. Tags should be installed every 1,000 feet between poles.
3. Buried cable signs should be installed every 1,000 feet between riser poles as well as on both riser poles.
4. Tag locations shown above are recommended locations; tags may be installed at additional locations as deemed necessary for adequate identification.
5. The Licensee shall affix a tag to the poles for each attachment belt.

A Revised 9/6/02

POLE ATTACHMENTS

POLE TAG REQUIREMENTS

Drawing is NOT to scale

A-99